

- > **Port size: 1/4" ... 1/2" (ISO G/PTF)**
- > **Excelon design allows in-line installation or modular installation with other Excelon products**
- > **High efficiency water and particle removal**
- > **Quick release bayonet bowl**
- > **Push to lock adjusting knob with tamper resistant accessory**
- > **Metal bowl with prismatic liquid level indicator lens**



Technical features

Medium:

Compressed air only

Maximum operating pressure:

Transparent bowl: 10 bar (145 psi)

Metal bowl: 17 bar (246 psi)

Pressure range:

0,3 ... 10 bar (4 ... 145 psi)

0,3 ... 4 bar (4 ... 58 psi) optional,

0,7 ... 17 bar (2 ... 250 psi) optional

Filter element:

40 µm standard, 5 µm optional

Port size:

G1/4, G3/8, G1/2,

1/4 PTF, 3/8 PTF 1/2 PTF

Gauge port:

Rc 1/8 with ISO G main ports

1/4 PTF with PTF main ports

Flow:

50 dm³/s max. at port size: G1/2

10 bar (150 psi) inlet pressure,

set pressure: 6,3 bar (91 psi) Δp: 1

bar (14,5 psi)

Filter element: 40 µm

Relieving:

Standard

Drain:

Manual or automatic

Automatic drain operating conditions (float operated):

Bowl pressure required to

close drain: > 0,3 bar (5 psi)

Bowl pressure required to

open drain: ≤ 0,2 bar (2.9 psi)

Minimum air flow required to

close drain: 0,1 dm³/s (0.2 scfm)

Manual operation: depress pin

inside drain outlet to drain bowl

Ambient/Media temperature:

Transparent bowl:

-34° ... +50°C (-30° ... +122°F)

Metal bowl:

-34° ... +80°C (-30° ... +176°F)

Version with gauge:

-34° ... +65°C (-30° ... +149°F)

Air supply must be dry enough

to avoid ice formation at

temperatures below +2°C (+35°F).

Materials:

Body: Die cast aluminium

Bonnet: Acetal

Metal bonnet: Zinc

Valve: Brass

Bowl: transparent PC alternative

transparent PC with steel guard

alternative aluminium

Liquid level indicator lens (metal

bowl): transparent PA

Filter element: sintered PP

Elastomers: CR & NBR

Technical data B73G - standard models

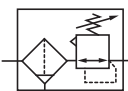
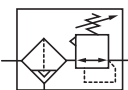
Symbol	Port size	Size	Drain	Pressure range		Filter element (µm)	Bowl	Weight (kg)	Model
				(bar)	(psi)				
	G1/4	—	Manual	0,3 ... 10	4 ... 145	40	PC (transparent)	0,70	B73G-2GK-QT3-RMN
	G3/8	Basic	Manual	0,3 ... 10	4 ... 145	40	PC (transparent)	0,70	B73G-3GK-QT3-RMN
	G1/2	—	Manual	0,3 ... 10	4 ... 145	40	PC (transparent)	0,70	B73G-4GK-QT3-RMN
	G1/4	—	Automatic	0,3 ... 10	4 ... 145	40	PC (transparent)	0,70	B73G-2GK-AT3-RMN
	G3/8	Basic	Automatic	0,3 ... 10	4 ... 145	40	PC (transparent)	0,70	B73G-3GK-AT3-RMN
	G1/2	—	Automatic	0,3 ... 10	4 ... 145	40	PC (transparent)	0,70	B73G-4GK-AT3-RMN

Option selector

B73G-***-*****-*******

Port size	Substitute
1/4"	2
3/8"	3
1/2"	4
Thread form	Substitute
PTF	A
ISO G parallel (standard)	G
Adjustment	Substitute
Knob (standard)	K
T-bar	T
Drain	Substitute
Manual (standard)	Q
Auto drain (standard)	A
Bowl	Substitute
Transparent (standard)	T
Metal	D
Transparent with guard	P

Gauge	Substitute
Without (standard)	N
With	G
Pressure range *2)	Substitute
0,3 ... 4 bar	F
0,3 ... 10 bar (standard)	M
0,7... 17 bar	S
Diaphragm	Substitute
Relieving (standard)	R
Non relieving	N
Element	Substitute
40 µm (standard)	3
5 µm	1

*2) Outlet pressure can be adjusted to pressures in excess of, and less than, those specified. Do not use these units to control pressures outside of the specified ranges.

Flow characteristics

Inlet pressure: 10 bar
Port size: G3/8, 40 µm element

Inlet pressure: 7 bar
Port size: G3/8, 40 µm element

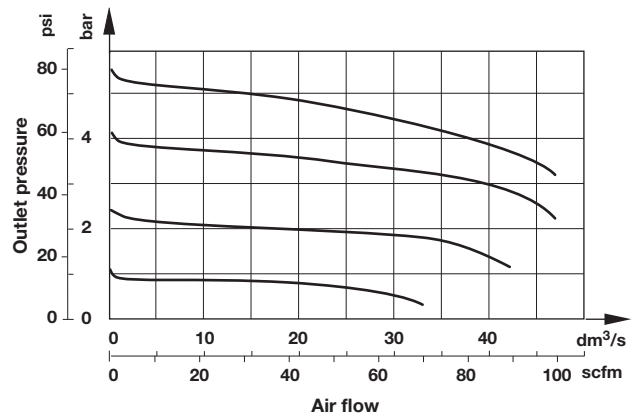
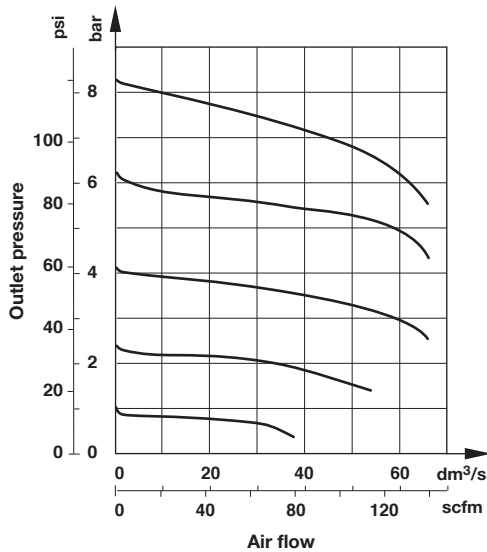

Accessories

<p>Wall mounting bracket</p> <p>Page 5</p> <p>4424-50</p>	<p>Neck mounting bracket</p> <p>Page 5</p> <p>4461-50</p>	<p>Panel nut</p> <p>5191-88</p>	<p>Quikclamp®</p> <p>Page 5</p> <p>4314-51</p>	<p>Quikclamp® with wall bracket</p> <p>Page 5</p> <p>4314-52</p>	<p>Tamper resistant kit</p> <p>4455-51</p>
--	--	--	---	---	---

<p>Quikmount pipe adaptor *1)</p> <p>Page 5</p> <p>G1/4: 4315-09 G3/8: 4315-10 G1/2: 4315-11 1/4 PTF: 4315-01 3/8 PTF: 4315-02 1/2 PTF: 4315-03</p>	<p>Porting block with three alternative 1/4" ports</p> <p>Page 5</p> <p>G1/4: 4316-52 1/4 PTF: 4316-50</p>	<p>2/2 Shut-off valves (for full technical specification see datasheet 8.180.600)</p> <p>Page 5</p> <p>G1/4: T73B-2GA-P1N G3/8: T73B-3GA-P1N G1/2: T73B-4GA-P1N 1/4 PTF: T73B-3AA-P1N 3/8 PTF: T73B-2AA-P1N 1/2 PTF: T73B-4AA-P1N</p>	<p>3/2 Shut-off valves (for full technical specification see datasheet 8.180.600)</p> <p>Page 5</p> <p>G1/4: T73T-2GA-P1N G3/8: T73T-3GA-P1N G1/2: T73T-4GA-P1N 1/4 PTF: T73T-3AA-P1N 3/8 PTF: T73T-2AA-P1N 1/2 PTF: T73T-4AA-P1N</p>
---	--	---	---

*1) Please use a Quikmount pipe adaptor if the Quikclamp® be mounted at inlet or outlet side.

Pressure switch

<p>Porting block for pressure switch</p> <p>0523109000000000</p>	<p>Pressure switch (0,5 ... 8 bar)</p> <p>0881300000000000</p>
---	---

Padlock

<p>Padlock (brass) with two keys *1)</p> <p>0613633000000000</p>

*1) For shut-off valves and tamper resistant kit.

Service kit

<p>Element</p>	<p>Service kit for manual drain</p>	<p>Service kit for auto drain</p>
	<p>40 µm</p> <p>B73G-KITM40R</p>	<p>B73G-KITA40R</p>
	<p>5 µm</p> <p>B73G-KITM05R</p>	<p>B73G-KITA05R</p>

Gauge

Center back connection, white face (for full technical specification see datasheet 8.900.900)

Pressure range			Ø	Thread size	Model
bar *1	Mpa	psi			
0 ... 6	0 ... 0,6	0 ... 84	50 mm	R1/8	18-015-012
0 ... 10	0 ... 1	0 ... 145	50 mm	R1/8	18-015-013
0 ... 25	0 ... 2,5	0 ... 362	50 mm	R1/8	18-015-014

*1) primary scale

Center back connection, black face for North America (for full technical specification see datasheet 8.900.900)

Pressure range			Ø	Thread size	Model
psig *1	bar	Mpa			
0 ... 60	0 ... 4	0 ... 0.4	2" (50 mm)	1/4 NPT	18-015-208
0 ... 160	0 ... 11	0 ... 1.1	2" (50 mm)	1/4 NPT	18-015-209
0 ... 300	0 ... 20	0 ... 2.1	2" (50 mm)	1/4 NPT	18-015-210

*1) primary scale

Drawings

Dimensions in mm
 Projection/First angle

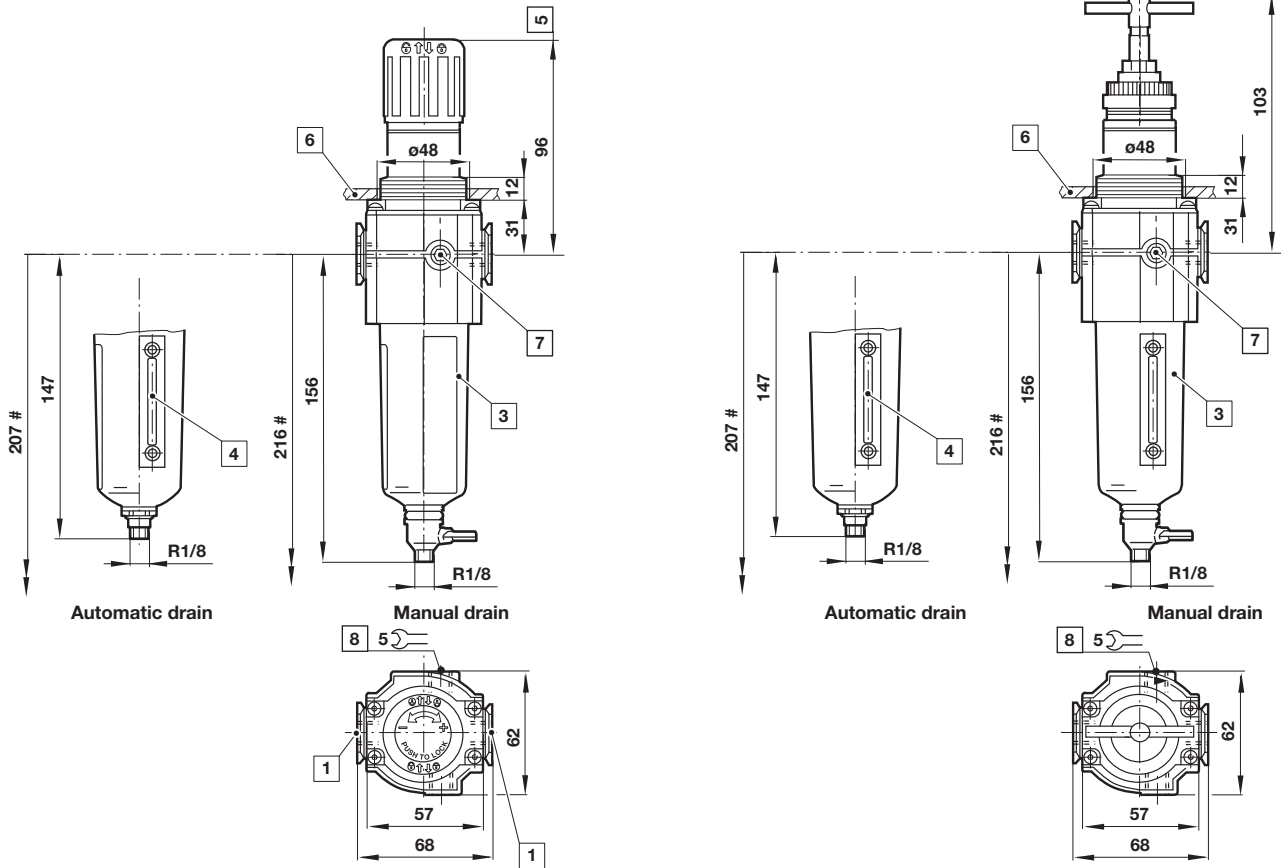

- # Minimum clearance required to remove bowl
- 1 Main ports 1/4", 3/8" or 1/2"
 - 3 Transparent bowl with or without guard
 - 4 Metal bowl with liquid level indicator lens
 - 5 Reduces by 4 mm with knob in locked position
 - 6 Panel thickness 2 ... 6 max.
 - 7 Gauge port 1/8" plugged
 - 8 Alternative gauge port plugged

Accessories

 Dimensions in mm
 Projection/First angle

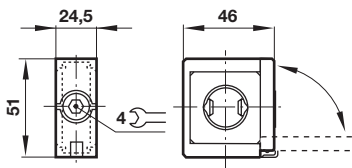
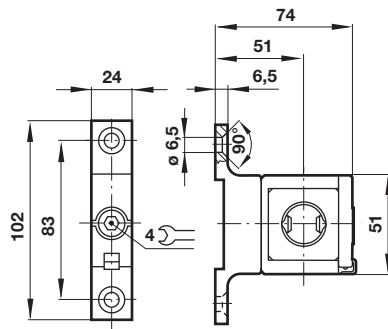
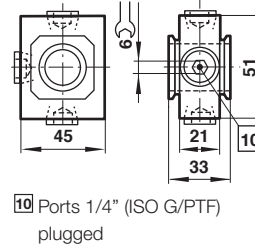
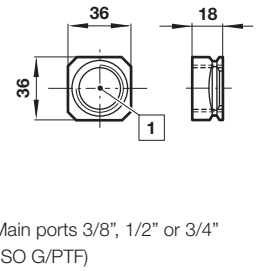
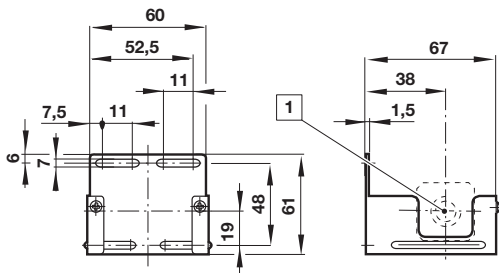
Quikclamp®

Quikclamp® with wall bracket

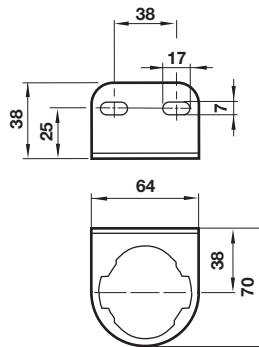
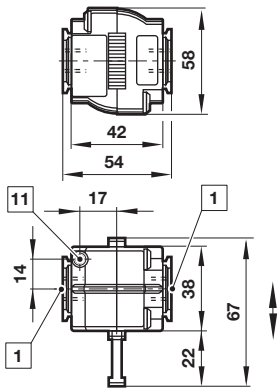
Porting block

Pipe adapter

Wall mounting bracket

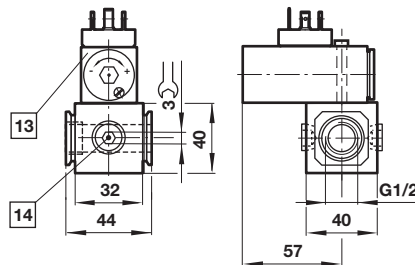
1 Main ports

Neck mounting bracket

Shut-off valves

1 Main ports 1/4", 3/8" or 1/2" (ISO G/PTF)

11 Exhaust port M5 at 3/2 valve only

Porting block for pressure switch

13 Pressure switch is not in scope of delivery

14 Alternative G1/2 ports plugged

Warning

These products are intended for use in industrial compressed air systems only. Do not use these products where pressures and temperatures can exceed those listed under »**Technical features/data**«.

Before using these products with fluids other than those specified, for non-industrial applications, life-support systems or other applications not within published specifications, consult IMI Precision Engineering, Norgren Inc.

Through misuse, age, or malfunction, components used in fluid power systems can fail in various modes. The system designer is warned to consider the failure modes of all component parts used in fluid power systems and to provide adequate safeguards to prevent personal injury or damage to equipment in the event of such failure.

System designers must provide a warning to end users in the system instructional manual if protection against a failure mode cannot be adequately provided.

System designers and end users are cautioned to review specific warnings found in instruction sheets packed and shipped with these products.